



COURSE INFORMATION

The Mulligan Concept Course Curriculum provides technical, post-graduate instruction in the manual therapy techniques of Mobilization with Movement™ taught by accredited teachers of the Mulligan Concept Teachers Association. This unique approach was discovered and developed by Brian Mulligan F.N.Z.S.P. (Hon), Dip. M.T. from Wellington, New Zealand. The Mulligan Concept™ is used for both assessment and treatment for musculoskeletal conditions throughout the entire body. When indicated the Mulligan Concept™ provides immediate relief of symptoms and long-lasting results. Mulligan courses with MWMUSA are focused on providing the participant with skills for evaluation, assessment and critical thinking to help maximize outcomes and establish a strong therapeutic alliance with your patients!

WHO CAN ATTEND?

The courses are designed for licensed health care practitioners including physical therapists, athletic trainers, occupational therapists, physical therapy assistants, medical doctors, osteopaths and chiropractors. The techniques are only to be practiced within the individual clinician's scope of practice.

BENEFITS OF HOSTING A COURSE:

A host receives

- **A Free** registration slot for the 10th, 20th, and 30th, registration for each course (valued at \$525 each = \$1575 potential savings in registration fees)
- **Free** Mulligan 7th edition book, package of manual therapy contact pads, and MWM mobilization belt for each free registration slot
- **Save** on travel, lodging, food and other expenses for each employee by hosting a course at your facility (**potential savings of approximately \$800 per employee**)
- Social Media marketing templates to help facilitate promotion of the course
- Organizations who choose to host the Upper Quadrant, Lower Quadrant, and Advanced courses receive **free lifetime access to the MWMusa tutorial library of over 100 video tutorials. Total Value of \$998!!!!**
 - Lower Quarter example: <https://vimeo.com/485823215>
 - Upper Quarter example: <https://vimeo.com/486281531>

Potential “Per Employee” Savings for each course of\$1,824!!!

COURSE OFFERINGS:

The core curriculum of Mulligan Concept courses in the USA are the Upper Quarter, Lower Quarter and the Advanced Course. Each of these courses consists of 13 hours of instruction over two days. Scheduling of the days and times may be flexible but typically is two weekend days from 8:00 am to 4:00 pm.



The 2 Day Upper Quarter Course will present the Mulligan approach to manual therapy for the Cervical and Thoracic spine as well as for the upper extremity. It will include lecture, patient demonstrations, and lab time to give the participants a thorough and in-depth coverage of the Mobilization with Movement approach for the Upper Quarter including headaches, tennis elbow, as well as a number of other common clinical presentations.



The 2 Day Lower Quarter Course will present the Mulligan approach to manual therapy for the lumbar spine and sacroiliac joint as well as for the lower extremity. It will include lecture, patient demonstrations, and lab time to give the participants a thorough and in-depth coverage of the Mobilization with Movement approach for the lower quarter including a variety of common clinical presentations throughout the region.



The 2 Day Advanced course will review and fine tune the participants skill level with the Mulligan approach to manual therapy for the whole body. In addition, it will provide instruction in the use of Pain Release Phenomenon techniques and compression techniques. It will include lecture, patient demonstrations, and lab time to give the participants an opportunity for in-depth problem-solving, refinement and advancement of the techniques in this approach. This will also prepare those who are interested in taking the Certified Mulligan Practitioner Exam.

The Certified Mulligan Practitioner Exam Program (CMP) is available for those practitioners (PT, ATC, Osteopaths and Chiropractors) who have completed the UQ, LQ and Advanced courses and wish to pursue further recognition and marketing of their competence in the Mulligan Concept. Those passing the written and practical CMP exams will be awarded the title of **Certified Mulligan Practitioner** and listed by geographical location on the Mulligan Concept website: www.bmulligan.com. More info on the CMP program can be found at <https://mwmusa.com/certified-mulligan-practitioner-exam/>



The 2 Day Advanced Course is usually combined into a 3 Day weekend format with the Certified Mulligan Practitioner Exam given on the third day.

CONTINUING EDUCATION CREDITS:

1. PRO CERT: State Boards of Physical Therapy (FSBPT) valid for PTs and PTAs holding license in: Alaska, Arkansas, Arizona, California, Colorado, Delaware, District of Columbia, Georgia, Hawaii, Idaho, Illinois, Indiana, Kansas, Kentucky, Michigan, Minnesota, Mississippi, Missouri, Montana, Nebraska, North Carolina, North Dakota, Oregon, Pennsylvania, Puerto Rico, Rhode Island, South Carolina, South Dakota, Tennessee, Utah, Vermont, Virginia, Wisconsin, Wyoming.

PTs and PTAs will receive:

Upper Quarter 12 CCUs

Lower Quarter 14 CCUs

Advanced Course 14 CCUs



2. NATA Board of Certification: (Provider P3566)
USA Athletic Trainers will receive 13 CEU for each course: UQ, LQ and Advanced Courses.



3. Certificate of attendance for 13 hours of instruction
If CEU credit above and beyond the above is desired, local chapter approval is the responsibility of the host. For those potential course participants or hosts that are not covered by the Procert and NATA CCUs/CEUs listed above and who wish to proactively enquire and apply for course **or** individual CEU credit in their state, MWMUSA is happy to help supply any documentation that they may be needed to file for CEU credit (see <https://mwmusa.com/course-list/ceus/>)

COSTS:

The standard cost in 2021 for the Upper Quarter, Lower Quarter and Advanced Courses is \$525 USD per participant. This includes instructor honorarium, all of the instructor's expenses including: travel, accommodations, incidentals, MCTA research fund contribution; handouts and course certificates. **Course Size:** up to 30 participants. Larger courses with multiple instructors are available upon request.

The standard cost in 2021 for the Certified Mulligan Practitioner Exam is \$500 USD per participant. This includes instructor honorarium for **two instructors**, pre-exam review session, written and practical examination process, one on one post-exam debriefing with each participant, all of the instructors' expenses including: travel, accommodations, incidentals and CMP certificates. **CMP Exam slots** are limited to no greater than 18 participants.

COURSE DETAILS:

1. **INSTRUCTOR RESPONSIBILITIES:** The instructor provides practical instruction of manual therapy techniques, production of course syllabus (handout), computer and projector, adhesive tape as needed, certificates of participation, and course evaluation forms. **(The instructor will need the course address and recommendations for local accommodation when the course is confirmed and will then make their own arrangements for travel and accommodation).**
2. **HOST FACILITY RESPONSIBILITIES:** The host needs to provide:
 - A. Room with sufficient room & tables capable of supporting a person lying on it (see second to last page schematic)
 - B. Chairs – preferably without arms
 - C. Projection screen or white surface to project onto
 - D. Small table with a power strip for the instructor’s computer / and instructor’s projector
 - E. Refreshments at breaks.
 - F. Spine model
 - G. Small or medium towels – one towel per every two participants.
 - H. Upper or lower extremity bone models are also useful but not required.
 - I. The names, titles and email addresses of attendees sent to instructor 5 days prior to the course

Only those professionals whose practice act and license permits them to perform joint mobilization are permitted to attend. The host shall screen their organization’s participants for proper credentials. It helps to designate a person responsible for on-site course administration. The host must ensure all of their organization’s participants are aware of “Participant Responsibilities” prior to the course.

3. **PARTICIPANT RESPONSIBILITIES:** attendees may wish to obtain the following recommended texts & accessories:
 - **The Mulligan Concept of Manual Therapy: Textbook of Techniques by Hing, Hall, Rivett, Vicenzino & Mulligan, 2015.**
 - **Manual Therapy, “NAGS”, “SNAGS”, “MWMS”, etc., 7th ed. Brian Mulligan.**
 - <https://mwmsusa.com/product/manual-therapy-nags-snags-mwms-etc-7th-edition/>
 - **Mobilisation with Movement: The art and science by Vicenzino, Hing, Rivett and Hall, 2011.**

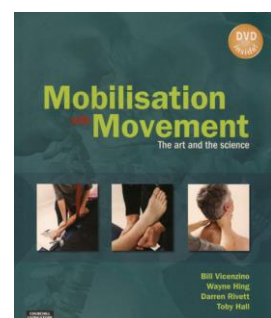
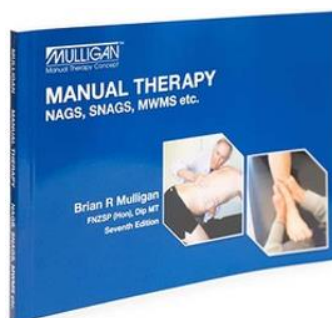
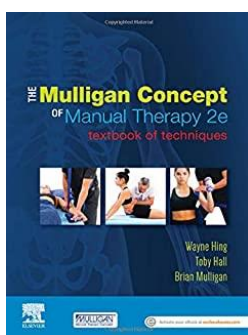

- **Books, Mobilization belts, and manual therapy contact pads can be obtained from: <http://mwmusa.com/marketplace/> The instructor may also have books, belts and contact pads available for purchase at a discount at the course. Also, a full tutorial series is available for purchase at the time of class registration for a 40% discount.**



- **<https://mwmusa.com/videos/>**
- **For UQ & Advanced courses, something to keep hair from hanging down the back of the neck is desirable.**
- **Participants must take personal responsibility for communicating to their lab partner and/or instructor any physical problem that might contraindicate having the techniques performed on them.**

CANCELLATION POLICIES:

Individual Participant Cancellation Policy: All cancellations must be submitted with written notice and received 14 days prior to the course date. Refunds, minus an administrative fee of \$50.00, are provided if cancellation is received in this timeframe. No refunds will be issued if notice is received less than 14 days before the course. If written notice is provided at **any time** prior to the start of the course, or within 1 week after, full course tuition may be transferred to another Mulligan Concept course within 1 year without the administrative fee.

Mulligan Concept Teacher's Association (MCTA) Right to cancel: The MCTA and its teachers reserve the right to cancel any course prior to the course date due to insufficient enrollment or unforeseen circumstances. In the unlikely event that this should occur, individual tuition fees will be returned in full (though life can be unpredictable, we will do everything in our power to avoid such a cancellation < 28 days before the course). However, MWMUSA and its teachers will not be held responsible for airline tickets, hotel reservations, or any other travel or personal expenses incurred by the registrant. MWMusa will make every attempt to contact you as soon as possible in the event a course must be canceled. Please consider this policy before making your travel arrangements.

Host Cancellation Policy: In the event that the host facility must cancel, a minimum of 4 weeks notice must be given in writing to the course instructor. This will allow sufficient time to notify all registered participants.

COURSE HOST CHECKLIST/ROOM SET UP:

Supplies (for up to 30 participants: adjust numbers to suit)

1. 30 chairs
2. 10-15 treatment tables
3. One small table/cart for instructor's projector and instructor's laptop
4. Power strip that accepts 2 three-pronged plugs
5. Screen or blank wall to project onto
6. Hand Towels (15-30) (for Upper Quarter and Advanced course)
7. Mulligan Concept texts and mobilization belts (if available)
8. Mobilization pads (if available)
9. Spine model (if available)
10. Upper and/or Lower extremity models (if available)

Suggested Room Schematic: (2-3 chairs per table)

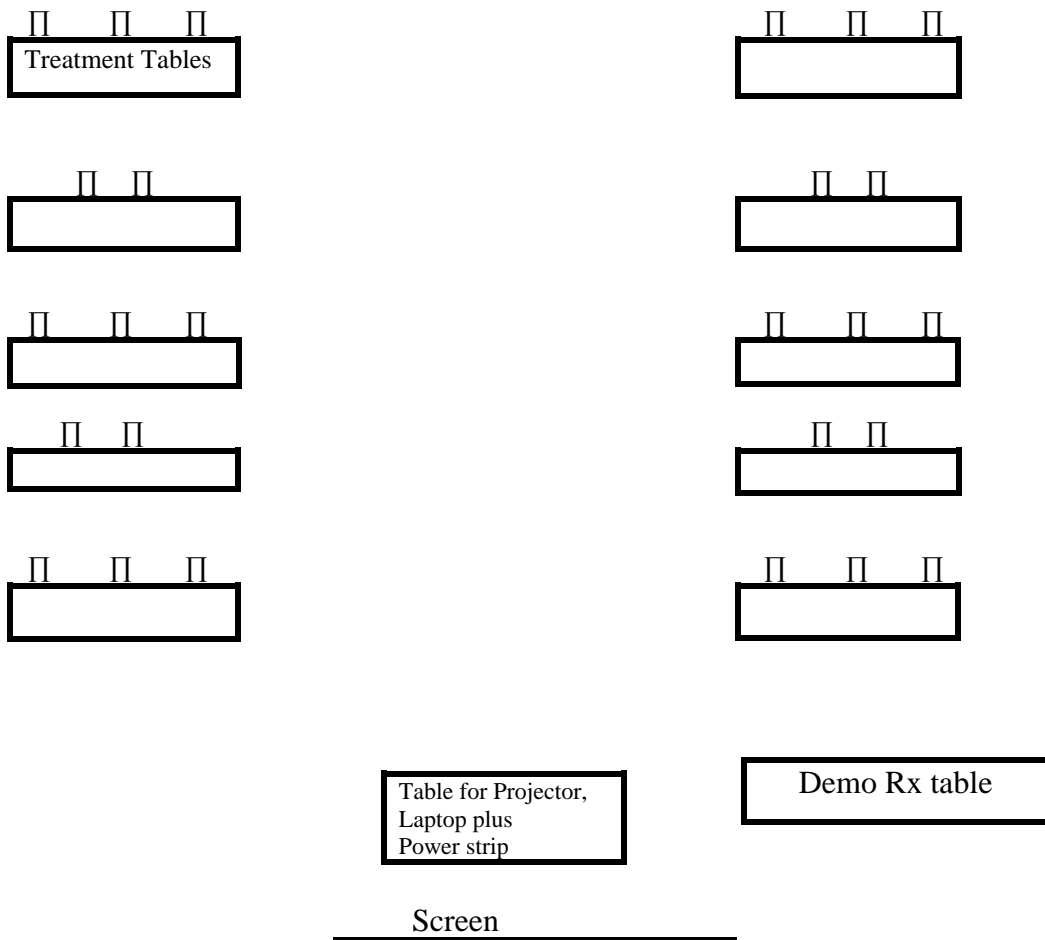

NOTE: In addition to the classroom set up, the CMP exam will require at least one small room with a door and a treatment table.

Please feel free to contact us by phone or email and we'll help you get set up for hosting a course.

Thanks for your interest in the Mulligan Concept and we look forward to working with you!

Sincerely,



Eric Dinkins, PT, DPT, OCS, Cert. MT, MCTA



Mark Thomson PT, DPT, OCS, FAAOMPT, MCTA

